

Raster 2,50 - Wire To Board System A - Gehäuse

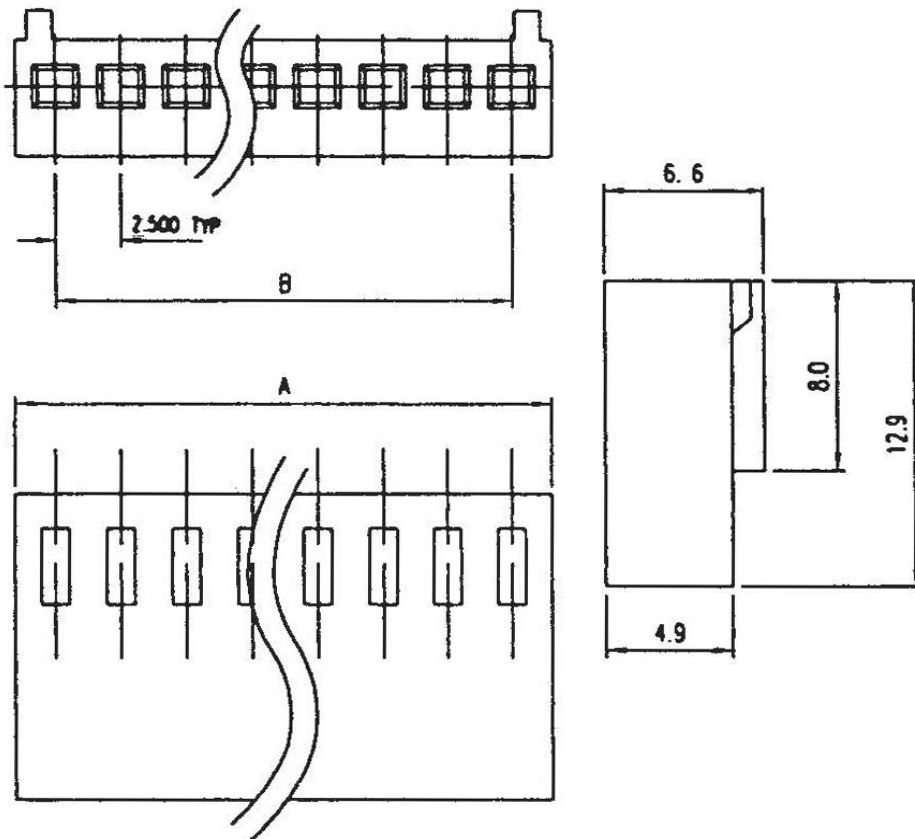

Technische Daten

Kontakte: 02 - 20
 Material: Nylon 66 UL94V-2

Kontakte	Maße	
	A	B
2	5	2,5
3	7,5	5
4	10	7,5
5	12,5	10
6	15	12,5
7	17,5	15
8	20	17,5
9	22,5	20
10	25	22,5
11	27,5	25
12	30	27,5
13	32,5	30
14	35	32,5
15	37,5	35
16	40	37,5
17	42,5	40
18	45	42,5
19	47,5	45
20	50	47,5

Bitte beachten Sie passend dazu:

[Wire To Board System A - Kontakt](#)
[Wire To Board System A - Stiftleiste](#)